



Gabbioneta Pumps®
Heavy Duty Process Pumps
RL Range

General information

The RL range process pumps are horizontal, radially split, centreline supported, single entry overhung impeller pumps, designed in a back pull-out configuration according to the latest edition of API 610 Standard.

RL pumps feature open Barske type impeller with radial vanes, specifically designed for low flow operation.

Main design features:

- Geometry of pump components optimised through hydraulic, structural, thermal and dynamic F.E.M. analysis to guarantee high product reliability
- Back pull-out construction for easy maintenance procedures
- Diffuser and shroud plate tailor-designed to best fit operating conditions
- Construction with replaceable shroud plate and without wear rings for constant hydraulic performances throughout pump life
- Centreline feet mounting for high temperature stability
- Bearing housing intrinsically contamination free, even in case of mechanical seal failure
- Fan cooling and/or finned bearing bracket
- Casing, bearing frame and baseplate stiff enough to assure minimum shaft deflections under heavy nozzle load conditions (extended life for seal and bearing)
- Seals and sealing systems in accordance with API 682 Std
- Baseplate overall dimensions according to API 610 recommendation
- A wide range of sizes and material combinations complete the variety of the offered products

Options

The following pump designs can be provided:

- Casing and cover with full cooling or heating jackets
- Stuffing box cooling water or heating jacket, easily accessible for inspection and mechanical cleaning
- Standard or special bearing isolators at both bearing housing ends
- Oil mist lubrication system (pure or purge)
- Water cooling for bearing bracket
- Baseplate available with three point gimbals mounting (FPSO services)

Main pumps applications refer to heavy duties on

- Oil & Gas
- Refineries
- Petrochemical and chemical plants
- Feedwater and power plant auxiliaries

Operating data

Capacity

up to 15 m³/h (65 USgpm)

Head

up to 200 m (650 feet)

Temperature

from -100°C (-150°F) to 450°C (850°F)

Design working pressure

up to 40 barg (600 psig)

Rotational speed

up to 3600 rpm

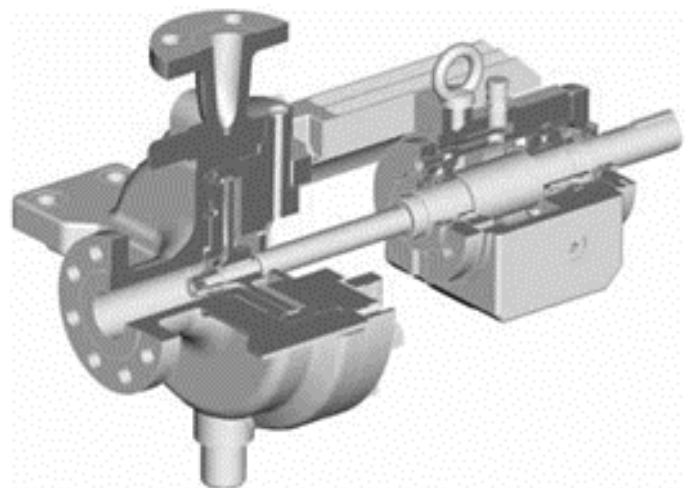

Overall dimensions

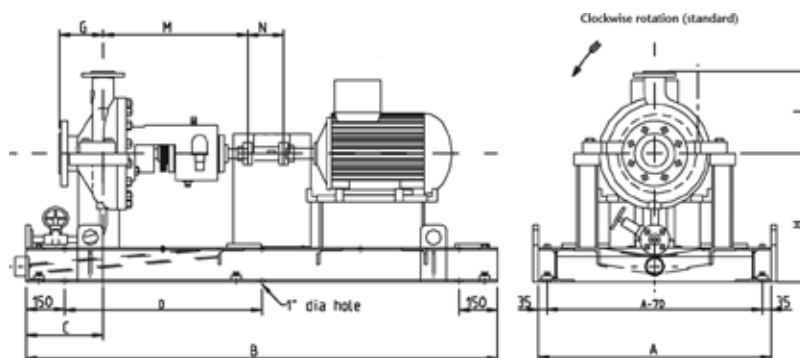

PUMP SIZE	NOZZLE SIZE	C	G	H	L	M	M	Max motor size	API base number	A	B	D	No. of bolts per side
RL 150 GN1	2"/1.5"	300	150	500	250	575	140	180	1/5, 1	755	1840/1530	770/615	3/3
RL 175 GN1	2"/1.5"	300	150	500	250	575	140	180	1/5, 1	755	1840/1530	770/615	3/3
RL 200 GN1	2"/1.5"	300	150	500	260	575	140	180	1/5, 1	755	1840/1530	770/615	3/3
RL 225 GN1	2"/1.5"	300	150	500	260	575	140	180	1/5, 1	755	1840/1530	770/615	3/3
RL 250 GN1	2"/1.5"	300	170	500	280	575	140	280	4/3, 5/3, 2/5	910	2445/2145/1840/1530	715/615/770/615	4/4/3/3
RL 275 GN1	2"/1.5"	300	170	500	280	575	140	280	4/3, 5/3, 2/5	910	2445/2145/1840/1530	715/615/770/615	4/4/3/3
RL 310 GN1	2"/1.5"	300	170	500	350	575	140	215	4/3, 5/3, 2/5	910	2445/2145/1840/1530	715/615/770/615	4/4/3/3
RL 350 GN1	2"/1.5"	300	170	500	350	575	140	215	4/3, 5/3, 2/5	910	2445/2145/1840/1530	715/615/770/615	4/4/3/3

Coverage Chart

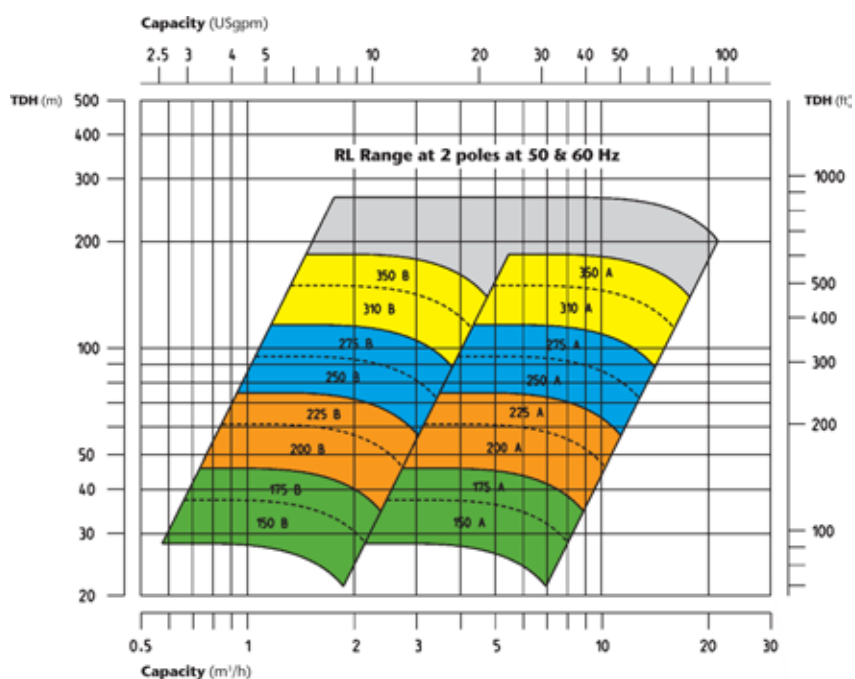

A century of experience

Since the foundation of the company in 1897, Gabbioneta Pumps® has been engaged in design and manufacture of high quality centrifugal pumps.

The products and the markets served progressively changed from water to chemical industry and finally, in the last thirty years, to API 610 heavy duty pumps for refinery and petrochemical industries.

Product development is based on a thorough interchange of marketing and operating experience within the company and in close cooperation with project and plant engineers.

Manufacturing is carried out in a factory equipped with several modern CNC machines and machine tools. Special note has to be given to the machining centers where pump casings can be machined completely with only two settings.

In-house facilities are designed to meet the performance and NPSH testing requirements of all pumps manufactured in the company in full compliance with API 610 Standards.

A quality assurance system certified in accordance with ISO 9001 ensures Gabbioneta Pumps® are of the highest quality.



RL pumps in Gabbioneta test room



Trillium Pumps Italy S.p.A.
Società Unipersonale

Gaetana Agnesi 1, 20834 Nova Milanese (MB), Italy
T: +39 0362 17331; Fax: +39 0362 1733209; E: gabbioneta.sales@trilliumflow.com

www.trilliumflow.com Certified: ISO 9001:2015, ISO 14001:2015, OHSAS 18001:2007